

SEC. B-B

SCALE 2:1

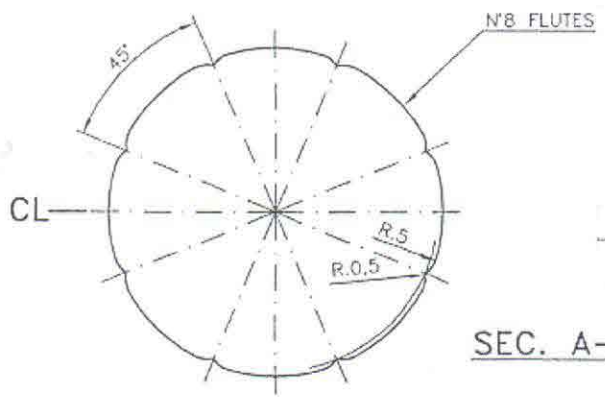
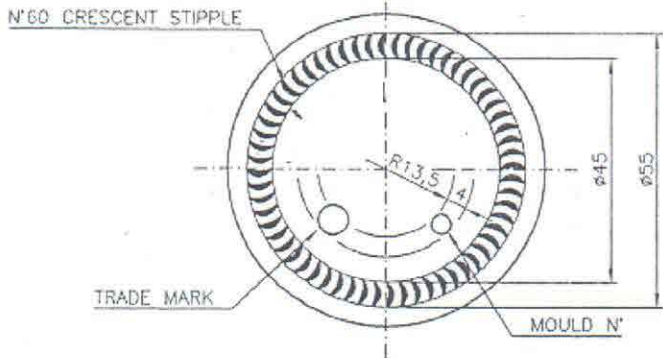

SEC. A-A

DATE		TITLE: 250ML HANDLE BOTTLE	BRIMFUL CAPACITY	265 +/- 6 ml
SCALE	FULL		FILLING CAPACITY	250 +/- 6 ml
DRAWN		CUSTOMER:	WEIGHT	255 +/- 5 gms
CHECKED			COLOUR	FLINT
APPROVED			FINISH	GF 304/28
ALL DIMENSIONS ARE IN MM				