

FINISH: \_\_\_\_\_ TO 82 (GPI 82-2040)  
 NECK DIAMETER : \_\_\_\_\_ 76.5

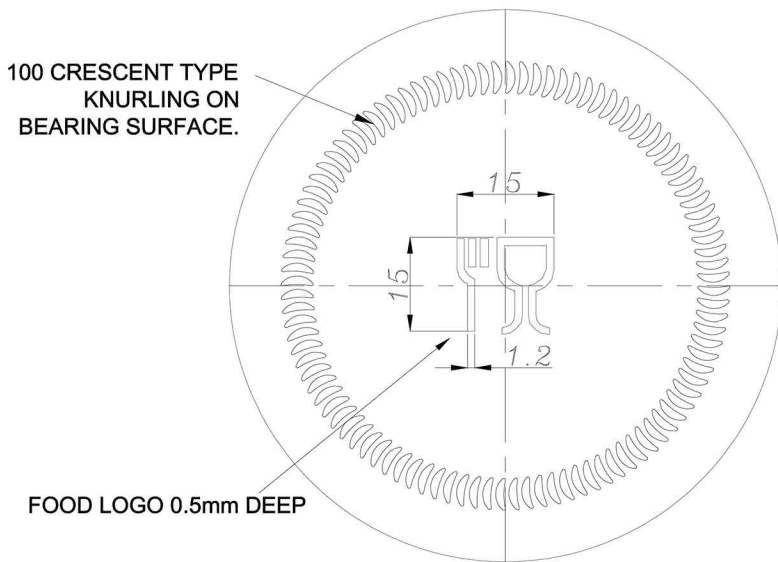
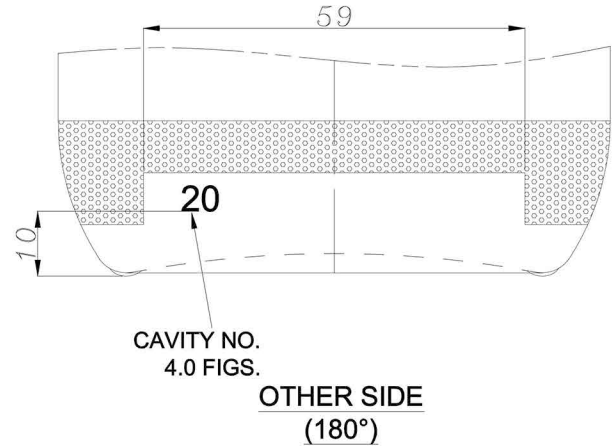
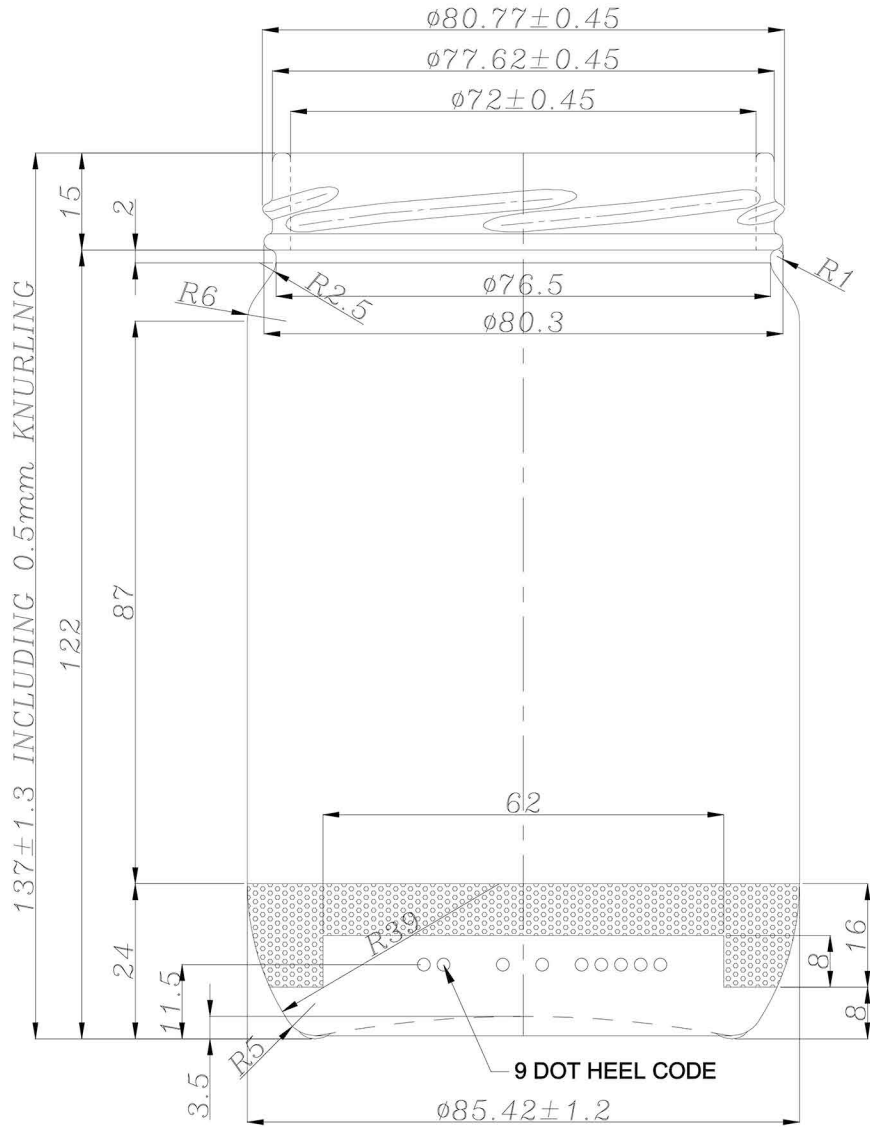

**BOTTOM VIEW**

**Additional Notes:**

- 1) Dimensions are for model purpose only and may be liable for change.
- 2) All engravings to be 0.40 proud and min. radius of 0.40 on corner unless noted otherwise.
- 3) Dimensions, parameters, weight and capacity was calculated based on supplied sample bottle.
- 4) Weight varies, depends on net capacity.
- 5) Do not scale drawing.
- 6) For customer copy only.

CONTAINER SPECIFICATION	
MATERIAL GLASS	WEIGHT 268GR.
COLOUR FLINT	CAPACITY NET
FINISH TO 82 (GPI 82-2040)	BRIMFUL CAPACITY 635±7.1ML
BORE DIAMETER SEE GLASS FINISH SPEC. DRAWING	FILL LEVEL
SERVICE NRB	VACUITY
DATABASE 635 JAR-BTL (WG009)	HEIGHT 137±1.3
TILT ANGLE 27.224°	PROCESS PB

REF	REVISIONS	
DESCRIPTION		
635ml JAR		CUSTOMER
DRAWN BY:		SCALE
DESIGN DEPARTMENT		1:1MM.
CHECKED AND REVIEWED BY:		SHEET
DESIGN REVIEW COMMITTEE		1OF1
APPROVED BY:		DWG NO.
QUALITY ASSURANCE		PAD00214
PRODUCTION MANAGER		