

24NO'S RIBS 0.4 mm PROJECTED OUT SIDE-SURFACE. 30° APART FROM EACH OTHER. AT THE TOP AND BOTTOM AS SHOWN.

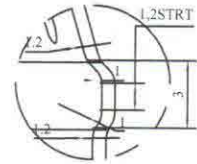

DETAIL D
SCALE 5:1

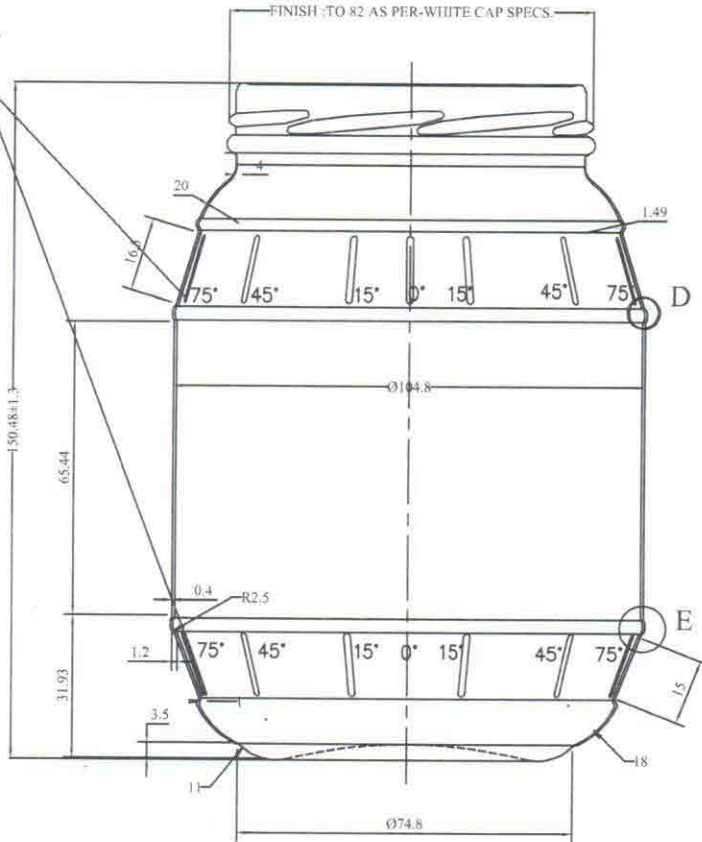
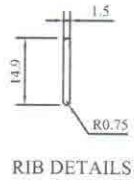
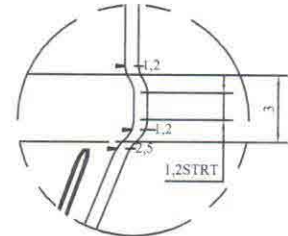

DETAIL E
SCALE 5:1

CRESCENT KNURLING- ON BEARING SURFACE. (72NO'Sx0.5mm DEEP)

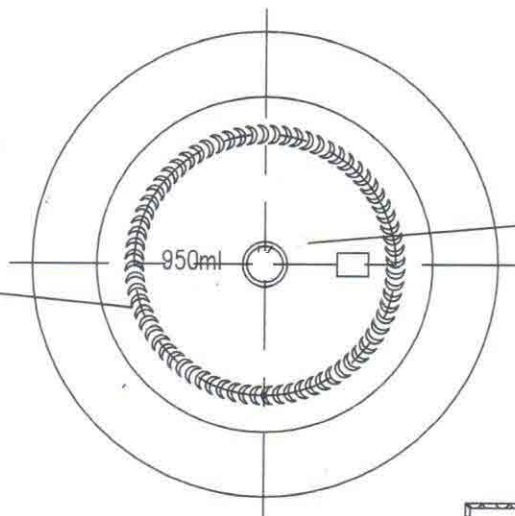

EMBOSS THE 950ml AND CAV.NO

CUSTOMER APPROVAL :-----

DATE :-----

PROCESS							
MINIMUM THROUGH BORE	N.A						
VACUITY	N.A						
GLASS COLOUR	FLINT	No.	REV. No.	REVISION	DATE	REV. BY	
MAXIMUM DEPTH OF STANDARD ENGRAVING	N.A	FILL-POINT CAP.	-----				PRODUCT NAME 950ml KHARSHOUFA JAR
MAX. GAS VOLUMES	N.A	BRIMFUL CAP.	950 ± 15ml				CUSTOMER :-----
REF.DRG No. EXIST BB DESIGN		WEIGHT	350 ± 8gr				DRAWN BY: 1 DATE: CHECKED:
PLANT		FINISH	TO 82				APPROVED BY: COLOUR
	1						SCALE DRAWING No. A4
		SURFACE TREATMENT	YES				NTS Rev. 00